

Hygienic 4060

Safety valve made of stainless steel, angle type, with stainless steel spring

→ Series Hygienic 4060



■ MATERIAL



■ SPECIFICATION



■ SUITABLE FOR

Liquids	neutral and non-neutral	
Air, gases and vapours	neutral and non-neutral	
Steam		

■ EXAMPLES OF USE

- For the protection of:
- processes, plants and containers in the food and pharmaceutical industry for air, neutral and non-neutral vapours and gases, steam and liquids
 - food industry
 - Dairy industry
 - breweries and beverage industry
 - pharmaceutical industry
 - Cosmetic industry
 - Medical technology
 - Clean Service applications

■ FEATURES

- Smooth and faultless surface finish optimized for cleaning process
- Minimal dead space in inlet area and no gaps in the valve
- Exposed and rinsed o-ring seals
- Shape of valve body avoids forming of puddles in the valve after it has opened
- Suitable for CIP/SIP due to pneumatic lifting device
- Gap-free installation of seals in contact with the medium
- Surface roughness in the primary area Ra < 0.75µm
- Optional: electropolished and/or mechanically polished
- Moulded diaphragm for separating the product space from the springhousing
- Dead space ratio L/D ~ 0,9

For explanation see chapter 1.1 General information on the hygienic valves. Definition of surface quality and options according to Chapter 1.1 Table V-301.

■ APPROVALS

TÜV-Type test approval 2111	D/G, F
EU type examination	S/G, L
ASME	S, G, L
CRN	S, G, L
TR ZU 032/2013 - TR ZU 010/2011	D/G (S/G), F (L)
KGS	G
Requirements	
DIN EN ISO 4126-1	VdTÜV Guideline SV 100
DGR 2014/68/EU	ASME-Code Sec. XIII
TRD 421	KGS AA 319
AD 2000 Data sheet A2	
Classification society	
American Bureau of Shipping	ABS

■ MATERIALS

Component	Material	DIN EN	ASME
Body	Stainless steel	1.4435	316 L
Inner parts, wetted	Stainless steel	1.4435	316 L
Upper section, other inner parts	Stainless steel	1.4404	316 L
Spring	Stainless steel	1.4310	302

Series 4060 ■ VALVE VERSION

t	Standard with diaphragm	for neutral and non-neutral media. Spring, moving parts and the environment are protected from being affected by the medium.
---	-------------------------	---

Parts which are difficult to clean in the guide, the spring housing and the spindle / disc combination are protected against soiling by elastomer diaphragm.

■ MEDIUM

GF	gaseous and liquid	Air, vapours, gases, liquids and - depending on safety valve version and seal - also for steam
----	--------------------	--

■ TYPE OF LIFTING MECHANISM

P	Pneumatic lifting device
L	with lifting lever
O	without lifting device, with additional gas-tight cap

■ AVAILABLE NOMINAL DIAMETERS AND CONNECTION SIZES

Connection type		SE4
Nominal diameter DN		25
Inlet DN	Standard	25
Outlet DN	25 (1")	■



■ TYPE OF CONNECTION INLET / OUTLET

SE4 / SE4	Standard	pipe connection / pipe connection	Pipe standard DIN 11850-2 / 11866-A
-----------	----------	-----------------------------------	-------------------------------------

■ SEALS / DIAPHRAGM

FKM	Fluorcarbon	Seals / diaphragms	FDA, USP	-20°C to +200°C
EPDM	Ethylene propylene diene	Seals / diaphragms	FDA, USP	-40°C to +170°C
HNBR	Hydrogenated acrylonitrile butadiene rubber	Seals / diaphragms	FDA	-20°C to +150°C

■ NOMINAL DIAMETERS, CONNECTIONS, INSTALLATION DIMENSIONS

Series Hygienic 4060: Connection, installation dimensions, ranges of adjustment		
Nominal diameter	DN	25
Connection type ¹⁾		Pipe
Connection inlet	da x t	29 x 1,5
Connection outlet	da x t	29 x 1,5
Installation dimensions in mm	L	80
	L1 ⁴⁾	132
	L2	120
	h	38
	h1	20
	H	177
	H1 ³⁾	212
Compressed air connection in mm	S	6
	do	24,5
Coefficients of flow ISO 4126-1	α_w (F)	0,33
	α_w (D/G) ²⁾	0,44
Coefficients of flow ASME Code Sec. VIII Div. 1	GPM/Sq.Rt.PSID (F)	9,22
	SCFM/PSIA (G)	6,22
	PPH/PSIA (S)	17,46
Weight	kg	3,3
	kg ³⁾	3,6
	kg ⁴⁾	3,7
Range of adjustment	bar	0,4 - 16
Range of adjustment ASME	psi	15 - 232

¹⁾ further connection size possible, Dimensions according to separate main dimension
²⁾ Coefficient of flow for D/G valid for 6 bar or more, for smaller set pressures see values in capacity table.
³⁾ Values for version with pneumatic lifting device
⁴⁾ Values for version with lifting lever

■ MAIN DIMENSIONS, INSTALLATION DIMENSIONS

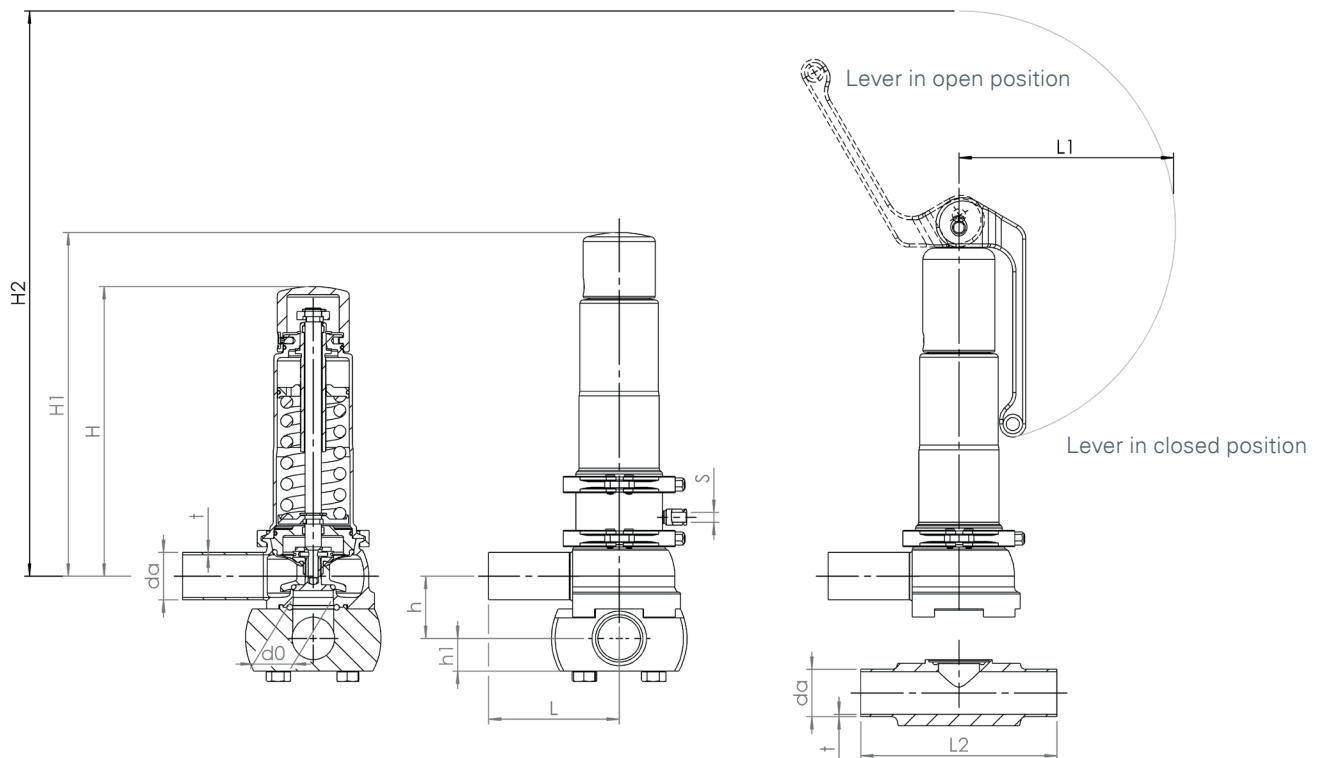

Series 4060 ■ INDIVIDUAL SELECTION / VALVE CONFIGURATION

Series	Valve version	Medium	Lifting device	Nominal diameter DN	Connection type		Connection type		Seal	Options	Set pressure	Quantity
					Inlet	Outlet	Inlet	Outlet				
4060	t	GF	P	25	SE4	SE4	25	25	EPDM	P07	3,2	1
4060	t	GF										
4060	t	GF										
4060	t	GF										
4060	t	GF										

■ TECHNICAL FINISHES, VARIANTS, ACCESSORIES

S62	Inductive proximity sensor, fitted, for indication of valve position, including connection cable 5m ¹	<input type="checkbox"/>
A05	Sealing wire / sealing on the fastening elements	<input type="checkbox"/>
		<input type="checkbox"/>

¹not available for version tGFL (with lifting lever)

■ PROPERTIES

DEFINITION OF SURFACE QUALITY AND OPTIONS ACCORDING TO CHAPTER 1.1 TABLE V-301

P01	Oil- and grease-free production	<input type="checkbox"/>	<input type="checkbox"/>
P05	Quality of surfaces in contact with media in inlet Ra <= 0,375	<input type="checkbox"/>	<input type="checkbox"/>
P07	Electropolished surfaces	<input type="checkbox"/>	<input type="checkbox"/>
P09	Surfaces mechanically and electropolished	<input type="checkbox"/>	<input type="checkbox"/>

■ CERTIFICATES / APPROVALS

C01	Factory certificate acc. DIN EN 10204 2.2 (WKZ 2.2)	<input type="checkbox"/>	C06	ATEX evaluation acc. to 2014/34/EU	<input type="checkbox"/>
C02	Test certificate acc. DIN EN 10204 3.1 (WPZ 3.1)	<input type="checkbox"/>	C07	SIL evaluation relating to IEC 61508-2	<input type="checkbox"/>
C03	Material test certificate acc. DIN EN 10204 3.1 (MPZ 3.1) (pressure retaining part)	<input type="checkbox"/>	C09	Seat tightness test with helium, leak detection method under vacuum incl. Factory Inspection Certificate 3.1 acc. to DIN EN 10204	<input type="checkbox"/>
C04	TÜV/DEKRA individual inspection acc. EN 10204 3.2 (TÜV/DEKRA-APZ)	<input type="checkbox"/>	C10	Certificate of oil- and grease free production	<input type="checkbox"/>
C05-1	Sealing material Manufacturer certification (FDA, USP,...), Please indicate description of certificate: _____	<input type="checkbox"/>			<input type="checkbox"/>

■ ADMISSIONS / ACCREDITATIONS

AA1	EC Type examination acc. to Directive 2014/68/EU	<input type="checkbox"/>	AK3	American Bureau of Shipping (ABS) type approval	<input type="checkbox"/>
AA2	TÜV component test acc. to VdTÜV specification sheet SV 100	<input type="checkbox"/>	AK6	Registro Italiano Navale (RINA) type approval	<input type="checkbox"/>
AA3	Certification acc. to ASME Boiler and Pressure Vessel Code, Sec. XIII (ASME)	<input type="checkbox"/>	AL	Individual inspection by notified body inspector – (body to be indicated): _____	<input type="checkbox"/>
AA4	EAC - certificate/declaration with passport for the valve and laser marking of the valve	<input type="checkbox"/>			<input type="checkbox"/>
AA7	Registration according to Canadian Registration Number (CRN)	<input type="checkbox"/>			<input type="checkbox"/>

■ ENQUIRY

Copy and send to: order@goetze.de.

■ CAPACITY TABLE ACC. TO ISO 4126-1 / AD2000 A2

Series Hygienic 4060: Blowing-off rates at 10% above set pressure			
Nominal diameter DN		25	
		d ₀ = 24,5 mm	
Set pressure bar (g)		I	II
0,4		144,3	119,0
0,7		193,7	155,5
1,0		239,2	190,4
1,5		319,1	252,2
2,0		395,3	310,6
Air I	2,5	465,4	363,9
Nm³/h	3,0	536,1	417,4
	3,5	604,6	469,1
Steam II	4,0	673,2	520,7
kg/h	4,5	741,8	572,2
	5,0	810,3	623,6
Water III	5,5	878,9	674,9
m³/h	6,0	947,5	726,0
	6,5	1016,0	777,2
	7,0	1084,6	828,4
	7,5	1153,2	879,5
	8,0	1221,7	930,5
	8,5	1290,3	981,5
	9,0	1358,9	1032,4
	9,5	1427,4	1083,4
	10,0	1496,0	1134,3
	11,0	1633,1	1236,3
	12,0	1770,3	1338,0
	13,0	1907,4	1439,6
	14,0	2044,5	1541,6
	15,0	2181,7	1643,6
	16,0	2318,8	1745,2

■ CAPACITY TABLE ACC. TO ASME-CODE SEC. VIII DIV. 1

Series Hygienic 4040: Blowing-off rates at 10% above set pressure			
Nominal diameter DN		25	
		d ₀ = 0,9646 inch (24,5 mm)	
Set pressure	psi (g)	I	II
	15	203,4	570,9
	30	296,7	832,8
	40	365,1	1024,9
	50	433,5	1217,0
	60	502,0	1409,0
Air I	70	570,4	1601,1
SCFM	80	638,8	1793,1
	90	707,2	1985,2
Steam II	100	775,6	2177,3
PPH	110	844,1	2369,3
	120	912,5	2561,4
Water III	130	980,9	2753,4
GPM	140	1049,3	2945,5
	150	1117,7	3137,6
	160	1186,2	3329,6
	170	1254,6	3521,7
	180	1323,0	3713,7
	190	1391,4	3905,8
	200	1459,8	4097,9
	210	1528,3	4289,9
	220	1596,7	4482,0
	230	1665,1	4674,0
	232	1678,8	4712,5

Pressure-/ temperature rating

PN 16 | Material: 1.4404 / 1.4435

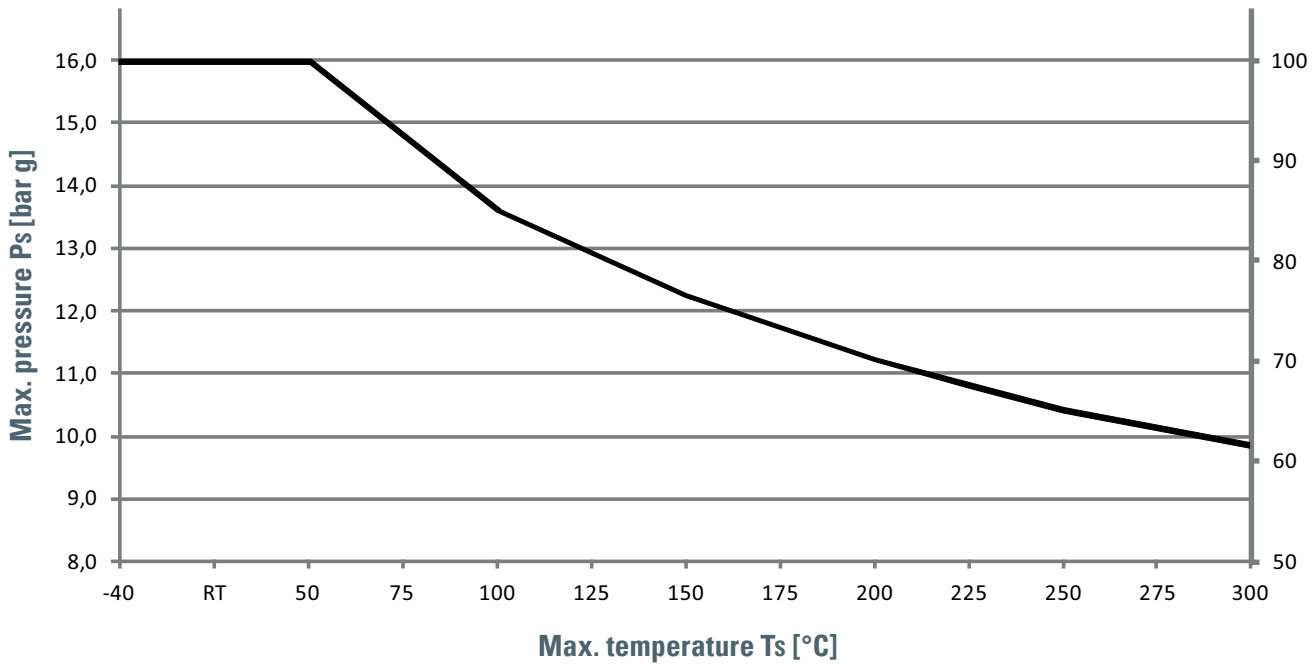

Max. Utilisation PN [%]

Control air pneumatic lifting device (max. 6 bar)

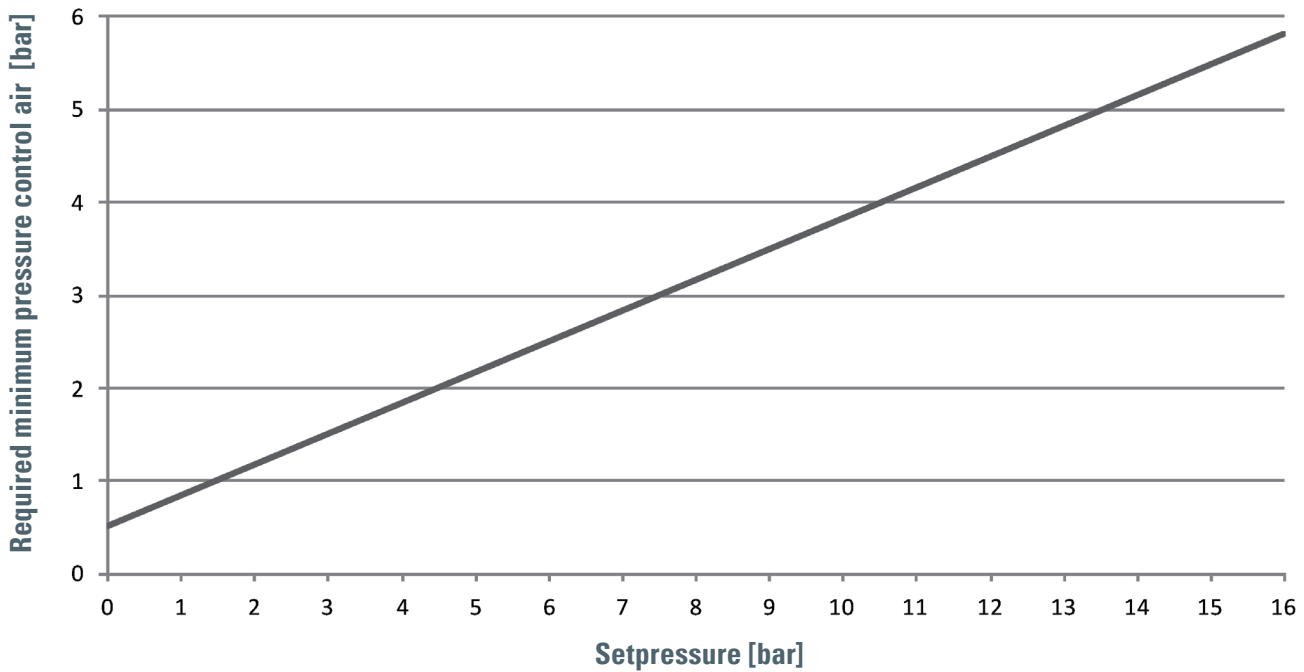

HYGIENIC AND ASEPTIC CONNECTIONS

Connection type	Drawing	Description	Standard	Pipe standard	400	400.5	4000	4020	4040	4060
KLSDIN KLSISO KLSASME KLSIX		Clamp connection Clamp connection Clamp connection Clamp connection	DIN 32676-A DIN 32676-B DIN 32676-C ISO 2852	Pipe standard DIN 11850-2 / 11866-A Pipe standard DIN EN ISO 1127 / DIN 11866-B Pipe standard BS 4825-1 / DIN 11866-C Pipe standard ISO 2037			X		X	X
GS1		Threaded ferrule connection	DIN 11851-SC	Pipe standard DIN 11850-2 / 11866-A			X		X	X
KS1		Taper nipple with groove cap nut	DIN 11851-SD	Pipe standard DIN 11850-2 / 11866-A			X		X	X
A-NKS1 A-NKS2 A-NKS3		Aseptic groove clamp connection Aseptic groove clamp connection Aseptic groove clamp connection	DIN 11864-3-NKS DIN 11864-3-NKS DIN 11864-3-NKS	Pipe standard DIN 11850-2 / DIN 11866-A Pipe standard DIN EN ISO 1127 / DIN 11866-B Pipe standard BS 4825-1 / DIN 11866-C			X		X	X
A-BKS1 A-BKS2 A-BKS3		Aseptic collar clamp connection Aseptic collar clamp connection Aseptic collar clamp connection	DIN 11864-3-BKS DIN 11864-3-BKS DIN 11864-3-BKS	Pipe standard DIN 11850-2 / DIN 11866-A Pipe standard DIN EN ISO 1127 / DIN 11866-B Pipe standard BS 4825-1 / DIN 11866-C			X		X	X
A-GS1 A-GS2 A-GS3		Aseptic threaded ferrule connection Aseptic threaded ferrule connection Aseptic threaded ferrule connection	DIN 11864-1-GS DIN 11864-1-GS DIN 11864-1-GS	Pipe standard DIN 11850-2 / DIN 11866-A Pipe standard DIN EN ISO 1127 / DIN 11866-B Pipe standard BS 4825-1 / DIN 11866-C			X		X	X
A-KS1 A-KS2 A-KS3		Aseptic collar connection with groove cap nut Aseptic collar connection with groove cap nut Aseptic collar connection with groove cap nut	DIN 11864-1-BS DIN 11864-1-BS DIN 11864-1-BS	Pipe standard DIN 11850-2 / DIN 11866-A Pipe standard DIN EN ISO 1127 / DIN 11866-B Pipe standard BS 4825-1 / DIN 11866-C			X		X	X
A-BF1 A-BF2 A-BF3		Aseptic flanged connection Aseptic flanged connection Aseptic flanged connection	DIN 11864-2-BF DIN 11864-2-BF DIN 11864-2-BF	Pipe standard DIN 11850-2 / DIN 11866-A Pipe standard DIN EN ISO 1127 / DIN 11866-B Pipe standard BS 4825-1 / DIN 11866-C			X		X	X
A-NF1 A-NF2 A-NF3		Aseptic grooved flanged connection Aseptic grooved flanged connection Aseptic grooved flanged connection	DIN 11864-2-NF DIN 11864-2-NF DIN 11864-2-NF	Pipe standard DIN 11850-2 / DIN 11866-A Pipe standard DIN EN ISO 1127 / DIN 11866-B Pipe standard BS 4825-1 / DIN 11866-C			X		X	X
SE4 SE5 SE6		Butt weld Butt weld Butt weld		Pipe standard DIN 11850-2 / DIN 11866-A Pipe standard DIN EN ISO 1127 / DIN 11866-B Pipe standard BS 4825-1 / DIN 11866-C					X	X
VC		Container flange at valve inlet							X	

Other connection types such as flange connection according to DIN EN 1092 / ASME B16.5, APV plain / grooved flanges, NA Connect, SMS threaded / tapered connection pieces are available on request.