

Lumistar Luminaire ESL 55-LED-Ex, Stainless Steel



II 2G Ex d IIC Gb
II 2D Ex tb IIIC T80°C Db

- **For mounting on sight glass fittings:**
This Ex-type sight glass luminaire is designed for universal applications and is ideal for use in combined sight and light ports (single-flange version) or with two separate ports (2-flange version).
- **The special advantages of Lumiglas LED technology:**
 - vibration-proof
 - long service life and operational reliability
 - continuous LED operation up to around 50,000 hours
 - optimal for fittings that are difficult to access
 - no heat radiation in the light aperture (cold light)
 - no unwanted additional heat in chemical and/or biological processes
 - extremely high-contrast illumination
- **Compact design, powerful light output:**
Glare-free illumination; suitable for circular sight glass fittings to DIN 28120/DIN 28121 or similar, for screw-type sight glass fittings in compliance with DIN 11851 and for sight glass fittings on flow indicators.
- **Application:** For illuminating visual flow indicators, pipelines, laboratory mixers, bio-reactors as well as the interior of tanks, hoppers, silos, agitators and other, normally closed, vessels and reactors in **potentially explosive environments**.
Gas: Zones 1 and 2, Dust: Zones 21 and 22.
- **Ideal for applications in sterile areas**
- **Protection class:** IP 65 and IP 67 acc. to DIN EN 60529
- **Operating conditions:** Independent of the internal pressure/vacuum in the vessel. On no account should a sight glass luminaire be used as a substitute for the cover flange or instead of the complete sight glass flange assembly or on its own to close a vessel port.
- **Lumistar luminaires of this type are approved for use in ambient temperatures of between -20°C and +40°C.**
- **Optional with 10° or 25° light aperture reflector**
- **Technical data Ex protection:**
This luminaire meets the essential safety and health requirements by complying with the regulations for
 - Gas**
EN 60079-0: 2009 General Requirements
EN 60079-1: 2007 Flame-proof Enclosures ,d'
Explosion group: IIC (includes IIA and IIB)
Temperature class: T6
 - Dust**
EN 60079-0: 2009 General Requirements
EN 60079-31: 2009 Protection by Enclosures ,t'
Explosion group: IIIC (includes IIIA and IIIB)
Temperature class: T80°C
- **EC-Type Examination Certificate:** BVS 09 ATEX E 169
 II 2G Ex d IIC T6 Gb
 II 2D Ex tb IIIC T80°C Db

CE 0158

3755.453 d



Lumistar luminaire ESL 55-LED-Ex

- **Operating voltage:**

24 V	AC/DC	LED 11 W/15 W
120-230 V	AC/DC	LED 11 W/15 W

 Protected by 1A miniature fuse.
Equipped with 3 or 6 high-power LEDs.
- **Voltage:** AC/DC
- **Simple electrical connection via integrated cable or via Ex d cable gland.**
- **Electrical connection options:**
 - Works-fitted connection cable (2 m standard length), resin-cast in screwed cable gland for pressure-tight cable entry, temperature-resistant up to 110°C.
Other length available on request: 10 m
 - By way of screwed cable gland acc. to EN 60079-14
 - Other types of cable glands and cables are shown in the table overleaf.
- **Fastening options:**
Luminaires for sight glasses on circular fittings and visual flow indicators are mounted on the cover flange by means of the hinged bracket. With screw-type sight glass fittings, the luminaire is attached to the slotted cover nut.

The Lumistar luminaire ESL 55-LED-Ex fits the following nominal sizes:

 - Circular sight glass fitting acc. to DIN 28120: DN 40
 - Circular sight glass fitting acc. to DIN 38121: DN 40
 - Sight glasses in flow indicators: DN 50
 - Screw-type sight glass fittings similar to DIN 11851:
 - From DN 50 up, the unit is mounted by way of a separate flange attachment.
 - From DN 80 up, the unit is secured using the hinged bracket.
- **In sterile environments, this Lumistar luminaire is fitted over the raised edge of the cover flange.**

• Dimensions and electrical data for Lumistar luminaire ESL 55-LED-Ex:

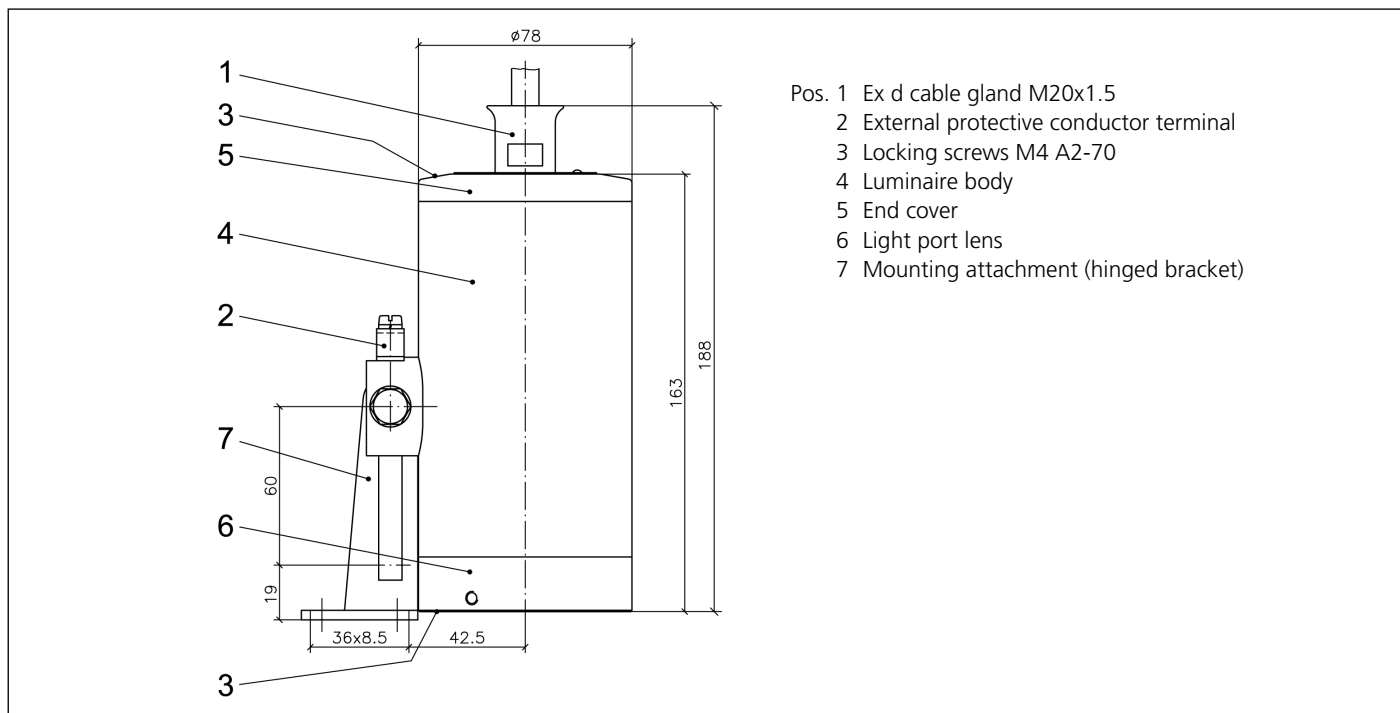

- Pos. 1 Ex d cable gland M20x1.5
 2 External protective conductor terminal
 3 Locking screws M4 A2-70
 4 Luminaire body
 5 End cover
 6 Light port lens
 7 Mounting attachment (hinged bracket)

• Components and materials:

- Luminaire body (4) and end cover (5):
Stainless steel 1.4404, polished
- Light port lens (6): Unit consisting of ring flange (stainless steel 1.4404, polished) and borosilicate glass

- Hinged mounting bracket (7): Stainless steel 1.4301 (see accessories)
- Cable gland (1): M20x1.5

• **Weight (with 2 m connecting cable): 3.8 kg**

• Connecting data: Temperature classification and electrical parameters (see also: EC Type-Examination Certificate)

No.	ESL 55-LED-Ex Variant	Part No.	Voltage Volt	Illuminant	Ambient temperature range -20°C ≤ T _a ≤ +40°C	
1	(24 V) 11 W	3541.552.00	24 ≈	3 LEDs	2G T6	2D T80°C
2	(120-230 V) 11 W	3541.553.00	120-230 ≈	3 LEDs	2G T6	2D T80°C
3	(24 V) 15 W	3541.555.00	24 ≈	6 LEDs	2G T6	2D T80°C
4	(120-230 V) 15 W	3541.556.00	120-230 ≈	6 LEDs	2G T6	2D T80°C

• Only combinations of the following cable entry glands and cables should be used:

Cable gland types	Cable types
HSK-M-Ex-d, Part No. 9103.124.00 M20x1.5, 1.4404 (by Hummel)	EVA flexible sheathed cable, Sinotherm 110, Part No. 3403.017.00, 3x1.5 mm ² , Ø 8.5 mm
KU1BPM20-Ex-d-Alpha X Part No. 9103.131.00 M20x1.5, stainless steel (by RST)	Ölflex Heat 180, Part No. 3403.045.00, 3x1.5 mm ² , Ø 8.9 mm
	Ölflex Heat 180, Silflex UR-AWG18, Part No. 3403.044.00, 5x1.0 mm ² , Ø 10.3 mm
	Ölflex Classic 110 black, Part No. 3403.051.00, 3x1.5 mm ² , Ø 10.1 mm

• Accessories:

No.	Component	Part No.
1	Luminaire mounting bracket (hinged)	0354.025.00
2	Luminaire mounting attachment, flanged adapter collar MV65	1356.039.00
3	Ex-timer switch	On request
4	Connecting cable	On request

• Order data:

e.g. Lumistar luminaire ESL 55-LED-Ex, (24 V) 11 W, Ex d IIC T6, with 2 m connecting cable, part no. 3541.552.00

All dimensions in mm unless stated otherwise. Subject to change without prior notice. 10.15