

**VISULEX Ex Camera K55P-Ex/K55N-Ex**



**II 2G Ex d IIC T6 Gb**  
**II 2D Ex tb IIIC T80°C Db**

- **Camera K55P-Ex/K55N-Ex with fixed lens:**  
During the installation process of this standard camera, its fixed lens is focused on the object to be monitored (outdoor area/facility or technical process components such as pressure vessels or agitators).
- **Design and applications:**
  - Pressure-resistant stainless steel body with built-in colour CCD camera, 1/3" CCD sensor, 1 lux light sensitivity
  - Approved for use in Ex zones 1 and 2 as well as zones 21 and 22
  - Type of protection: IP 65
- **Ambient temperatures:** between -5°C and +45°C
- **EC type examination certificate:** BVS 15 ATEX E 056 X  
 II 2G Ex d IIC T6 Gb  
 II 2D Ex tb IIIC T80°C Db
- **Ignition protection type:** Ex d
- **Explosion groups:** II C (incorporating II A and II B)  
IIIC (incorporating IIIA and IIIB)
- **Lens with viewing angle:** 28°-60°  
Minimum lens-to-object distance: 80 mm (see data overleaf)
- **Electrical connection:**
  - Link-up is established via an external connection box included in the scope of supply. (Assembly should be carried out in a non-Ex area!)
  - Terminal box: Primary 100-230 V 50/60Hz, secondary 12 V DC
  - Protection class: IP 40
  - Camera:  
Supply voltage: 12 V DC (supplied by the power adapter unit)  
Rated power: up to 7.5 W

CE 0158

3755.381



VISULEX camera K55P-Ex with fixed lens



Terminal box for VISULEX camera K55P-Ex

- **Control line:**
  - Coaxial cable with four cores and PUR sheathing
  - Length: up to 100 m (between camera and terminal box)
- **Weight:** 3.2 kg without control line

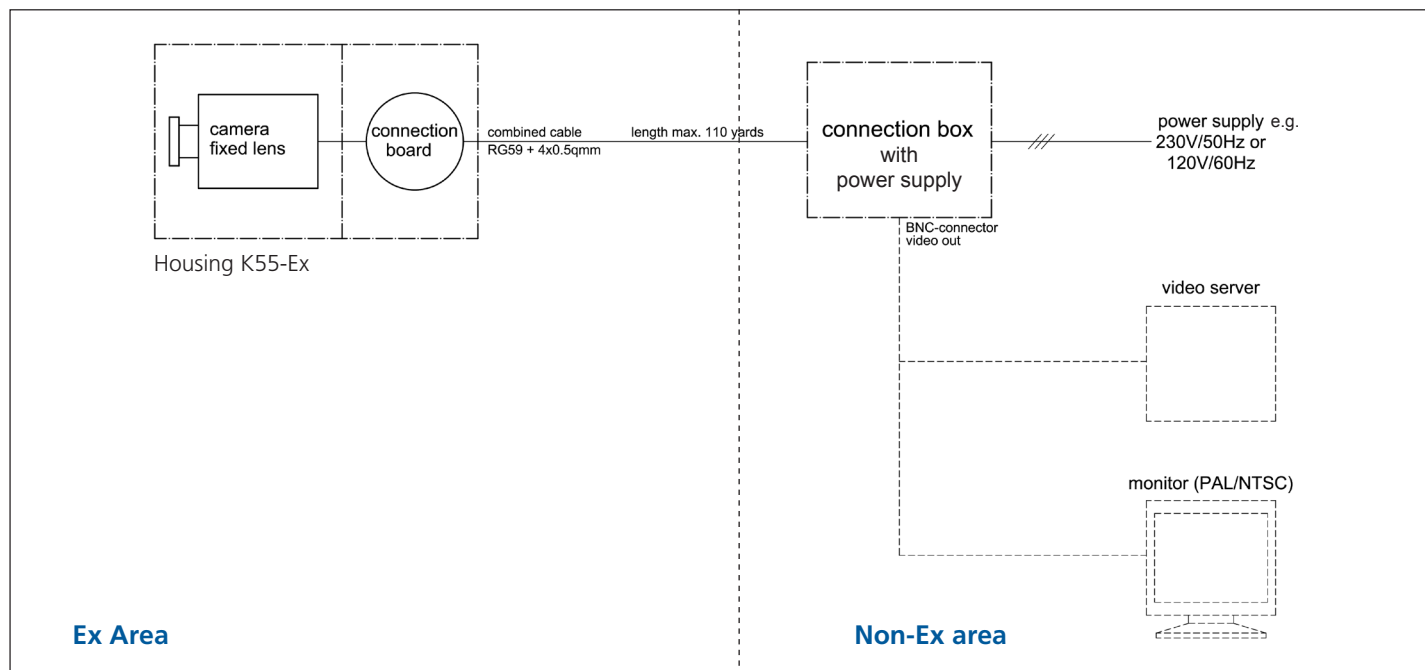

• **Mounting:**

Similar to the internationally renowned Lumistar luminaires, the camera is secured to the cover flange of a circular sight glass fitting (to DIN 28120 or similar) using the hinged bracket included in the scope of supply (hinged bracket - 1.4301). Alternatively, the special camera head can be mounted by way of a flanged adapter.

• **Illumination:**

- If there is not sufficient natural light in the vessel, an appropriately dimensioned Lumistar luminaire can be additionally installed.
- A separate arrangement consisting of light glass and camera glass is a further option for consideration. This combination depends on the process and the reactor size as well as on the surface of the vessel, the medium in question, and the angle of incidence.
- Consistently uniform illumination should be ensured.

• **Dimensions and technical data for VISULEX camera K55P-Ex/K55N-Ex:**

Camera	PAL	NTSC
Camera standard	CCIR (Europa)	EIA (USA)
Image sensor	1/3"-CCD	1/3"-CCD
Pixels	approx. 440,000	approx. 380,000
Light sensitivity	1 lux	1 lux
Resolution	480 lines (horizontal)	480 lines (horizontal)
Electronic shutter speeds	automatic, 1/1-1/10.000	automatic, 1/1-1/10.000
Signal-to-noise ratio	>48 dB	>48 dB
Aperture control	automatic	automatic
Colour system	PAL 752 x 582	NTSC 768 x 492

Power supply unit	Primary	Secondary
Voltage and power	100-230 V AC 50/60 Hz 7.5 Watt	12 V DC 3 Watt
Dimensions mm (H x W x D)	65 x 108 x 120	

Please note: Power supply unit for 24 V DC/12 V DC available on request.

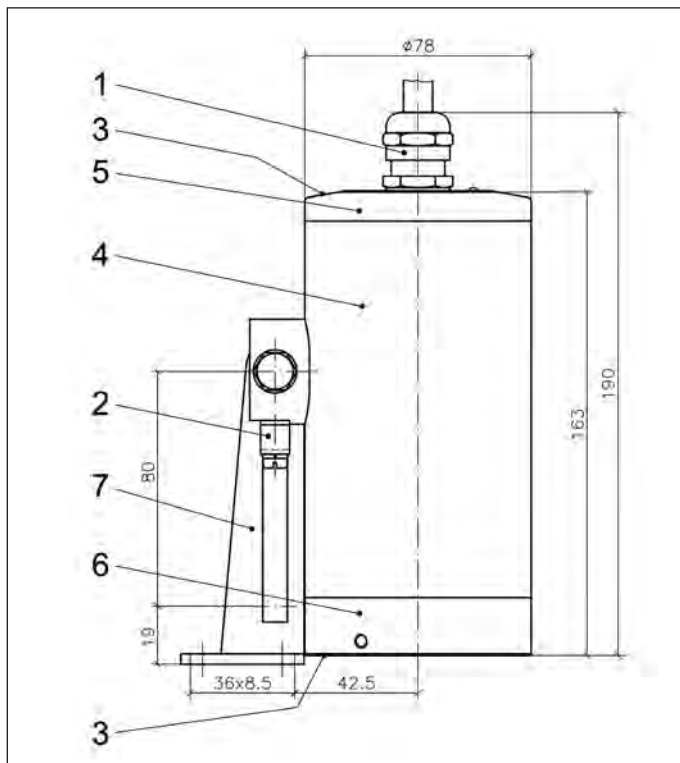

• **Order data:**

Item	Viewing angle	Part No.
1	60°	4502.019.00
2	54°	4502.023.00
3	39°	4502.020.00
4	28°	4502.024.00

**For example:**

- VISULEX camera K55P-Ex or VISULEX camera K55N-Ex
- Viewing angle, see table
- Control cable, please specify length in full metres (max. 100 m)
- Terminal box with power supply
- Mains connection cable (USA, GB, D, etc.)

- 1 Cable entry gland, M20 x 1.5 Ex d
- 2 Protective conductor terminal, external
- 3 Locking screws M4 A2-70
- 4 Body
- 5 Connection cover
- 6 Sight glass lens
- 7 Body mounting (hinged bracket)

All dimensions in mm unless stated otherwise. Subject to change without prior notice. 06.15