

Lumiglas Luminaire Series USL 05

- for use with sightglass fittings -

Application:

This ultra-compact luminaire provides for integral light/sight port (single flange version) or separate light and sight port (dual flange version) illumination of visual flow indicators, pipelines, laboratory mixers and other closed vessels and reactors. The USL 05 is suitable for food processing and is designed for Non Hazardous Areas. The luminaire must never be inserted into a vessel wall as sealing element, i.e. without appropriate sightglass disc and fitting.

Sightglass Styles and Size:

This powerful, ultra-compact luminaire is designed to give glare free illumination in combination with circular sightglasses of the following styles and sizes:

- circular weld-on Model DIN 28120 size DN25 and larger
- circular ANSI or DIN Flange Bolt-on size 1" (DN40) and larger
- visual flow indicators size 1/2" and larger
- circular weld-neck Series MV 65 and larger
- sanitary clamp connection size 1" and larger

Protection:

Dust and waterjet proof to IP 65 to EN 60 529/DIN VDE 0470 Part 1.

Ambient Condition Operating Range:

The unit is independent of any internal vessel pressure or vacuum. It is suitable for ambient temperatures of 80 °C at the cable gland. When ambient temperature exceeds 40°C, consult factory when ordering.

Power supply:

The unit can be fitted with various halogen lamps, and thus is suited for AC or DC voltage.

- with built-in transformer (PTC-protected)
 - supply 120 V; halogen lamp 12V/5 W
 - supply 230 V; halogen lamp 12V/5 W
- without built-in transformer
 - supply 12 V; halogen lamp 5 W or 10 W
 - Mini Spot halogen reflector lamp 20 W
 - supply 24 V; halogen lamp 50 W
 - Mini Spot halogen reflector lamp 20 W
 - supply 120 V; halogen lamp 50 W

Lamp sockets:

Please see table overleaf

Transformers:

Separate transformers with 12 V or 24 V secondary voltage are available.

Installation:

The luminaire is usually bolted with its hinged bracket to the respective sightglass assembly, such as the cover flange of a bolted circular sightglass or the slotted cover nut of a screwed flange sightglass. The necessary M6 bolt is furnished with the luminaire.

Lamp Change:

- switch off the luminaire and disconnect the power supply
- take special spanner to unscrew the glass lens ring
- replace halogen lamp with lamp of same type and size, ensure bare fingers do not touch the glass
- refit luminaire glass cover tightly and reconnect power



Lumiglas luminaire USL 05 with hinged bracket



Lumiglas luminaire USL 05, pivoted back off the sightglass

ISO 9001 QA CERTIFICATE
GERMAN MANUFACTURER:
F.H. PAPPENMEIER AWARDED QA APPROVAL CERTIFICATE



Dimensions and Electrical Data for Lumiglas Luminaire USL 05

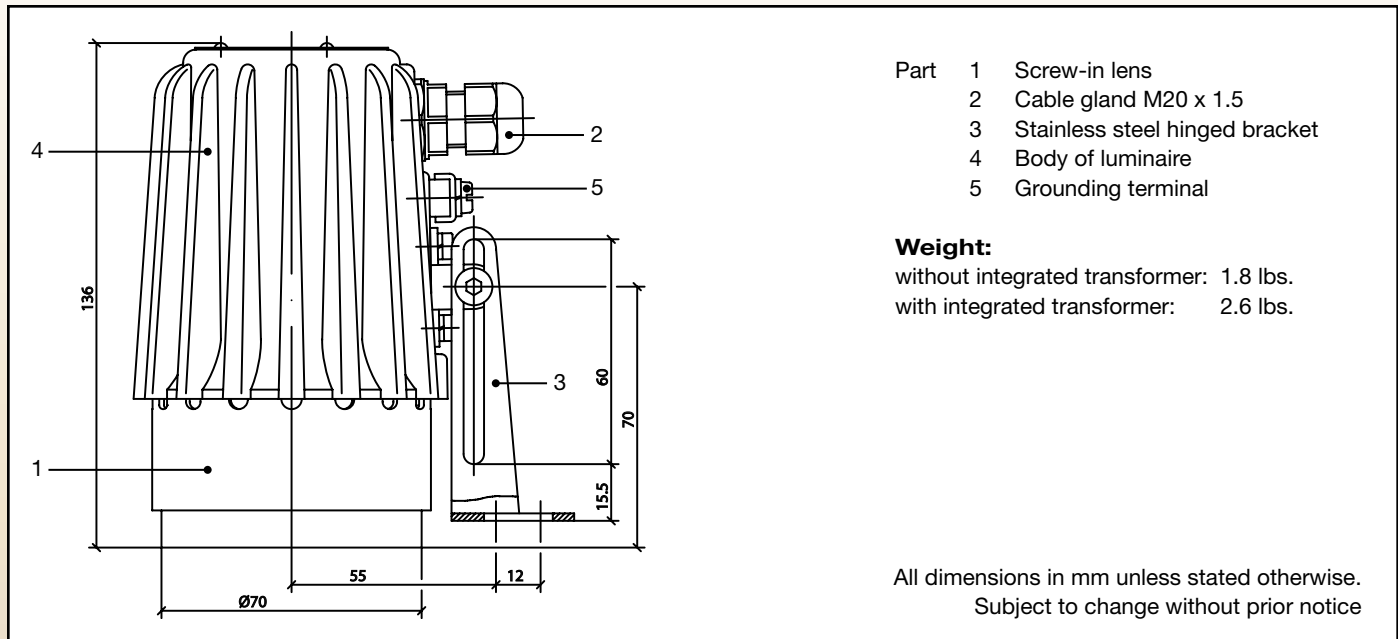

- Part 1 Screw-in lens
 2 Cable gland M20 x 1.5
 3 Stainless steel hinged bracket
 4 Body of luminaire
 5 Grounding terminal

Weight:

without integrated transformer: 1.8 lbs.
 with integrated transformer: 2.6 lbs.

All dimensions in mm unless stated otherwise.
 Subject to change without prior notice

• Components and materials:

- Body of luminaire made of non-corrosive cast aluminium alloy, GK-AISi10Mg
- Grounding terminal: The interior of the lamp is already fully wired; there is an additional grounding terminal on the outside of the housing.
- Light aperture: Unit made of aluminium ring and glass with Viton seal
- Mounting parts: Stainless steel 1.4301 (see accessories)

• Connecting data:

Part	USL 05	Part No.	Nominal Voltage	Integral Transformer	pushbutton	timer	Halogen Filament Lamp		
							Voltage/W	Socket	Part. No.
1	(230V/12V) 5W	0500-A4A1AN0N	230~	with	with	without	12V/5W	G4	BLB L5 G4N
2	(120V/12V) 5W	0500-A7A1AN0N	120~	with	with	without	12V/5W	G4	BLB L5 G4N
3	(24V) 20W	0500-A2C1AN0N	24≈	without	with	without	24V/20W	G4	BLB H20 G4S
4	(24V) 20W	0500-A2CNAN0N	24≈	without	without	without	24V/20W	G4	BLB H20 G4S
5	(24V) 20W	0500-A2C1AN0N	24~	without	with	with	24V/20W	G4	BLB H20 G4N
6	(24V) 50W	0500-A2F1AN0N	24≈	without	with	without	24V/50W	GY6.35	BLB H50 GYN
7	(24V) 50W	0500-A2FNAN0N	24≈	without	without	without	24V/50W	GY6.35	BLB H50 GYN
8	(230V) 50W	0500-A4F1AN0N	230≈	without	with	without	230V/50W	GZ10	BLB E50 GZ10
9	(230V) 7W-LED	0500-A4KNAN0N	230~	without	without	without	230V/7W LED	GZ10	Call Factory

• Accessories:

- 1 hinged bracket for mounting
- 2 flange adapter for mounting luminaire, stainless steel luminaire, stainless steel
- 3 timer (external) for time-dependent illumination, Lumiglas timer push-button
- 4 claw spanner for screw-in lens, for opening the luminaire

• Order data:

e. g. Lumiglas luminaire USL 05, 24 V/20 W, without integrated transformer, with pushbutton, without timer, with hinged bracket, part no. 0500-A2C1AN0N

