

Luminaire Series USL15/35 Stainless Steel

The world's brightest mid-size sight glass luminaire:

LED luminaire is three times brighter than a typical sight glass light, offering an unprecedented view of processes.

The advantages of LumiStar2000 LED technology:

- Ultra-bright LED provides 2000 lumens at full brightness, three times the light output than a typical 100-Watt halogen light
- Total internal reflection (TIR) lenses with 20-degree beam angle, ideal for vessel illumination through sight glass with maximum light output and less than 5% loss of light output. Other angle options available.
- Capable of continuous operation
- Cool white, 5500K color temperature, optimized for stainless-steel vessels (warm white and neutral white LEDs optional). For additional information ask for technical report TR-LED01
- Cool operation with temperature-based current limiting and automatic dimming; over temperature shutdown
- LEDs have long service life and are vibration and impact resistant
- No heat radiation into process vessel (cold light output)

Application:

Brightly illuminate process vessels for a clear view of processes in the brewery, chemical, pharmaceutical, bio-tech and food processing industries. It mounts on sight glass fittings for use in combined sight and light ports (single port version) or arranged separately (two port version). For illuminating brew kettles, bioreactors, mixers, filters and the interior of tanks, hoppers, silos, agitators, separators, pipelines and other – usually closed – containers in **non-hazardous areas**.

Fits the following nominal sizes:

- Circular Weld-On Sight Glass fitting to DIN 28120: from Size DN 40 (2" view diameter)
- Circular ANSI Bolt-On Sight window: from size 2"
- Visual Flow Indicators: from size 2"
- Circular Weld-Neck Sight Glass fitting series MV: from DN 50
- Sanitary Clamp Connection Series MetaClamp: from 2"

Protection:

- Dust and waterjet tight to NEMA 4 & 4X
- Dust and waterjet tight to IP 65 to DIN EN 60529/DIN VDE 0470 Part 1

Operating conditions:

Independent of internal pressure/vacuum in the vessel, standard LumiStar2000 luminaires are approved for use in ambient temperatures from -40°C up to +80°C at the cable entry gland. **Under no circumstances should these luminaires be used for sealing vessel openings - an appropriate sight glass fitting must be used at all times.**

Electrical data:

This LumiStar2000 luminaire is equipped with a factory light mounted cable gland or 5-pin M12 connector. Supplied with a 3 meter power cable, other lengths available.

Operation:

- Smart design with four modes of operation: flashlight mode (momentary), timed mode, continuous mode, and dimmer mode
- Factory-programmable options include: timer duration, initial brightness, and LED on at power up
- Remote switch available with optional wireless switch



LumiStar2000 Luminaire Series USL35 with MetaClamp® Sanitary Clamp Connection



LumiStar2000 Luminaire Series USL15 with Mounting Bracket

Operating voltage:

- Low Voltage: 24V (AC or DC), 12V DC available
- High Voltage: 110-240V AC

Dimensions and electrical data for LumiStar2000™ luminaire USL15/35:

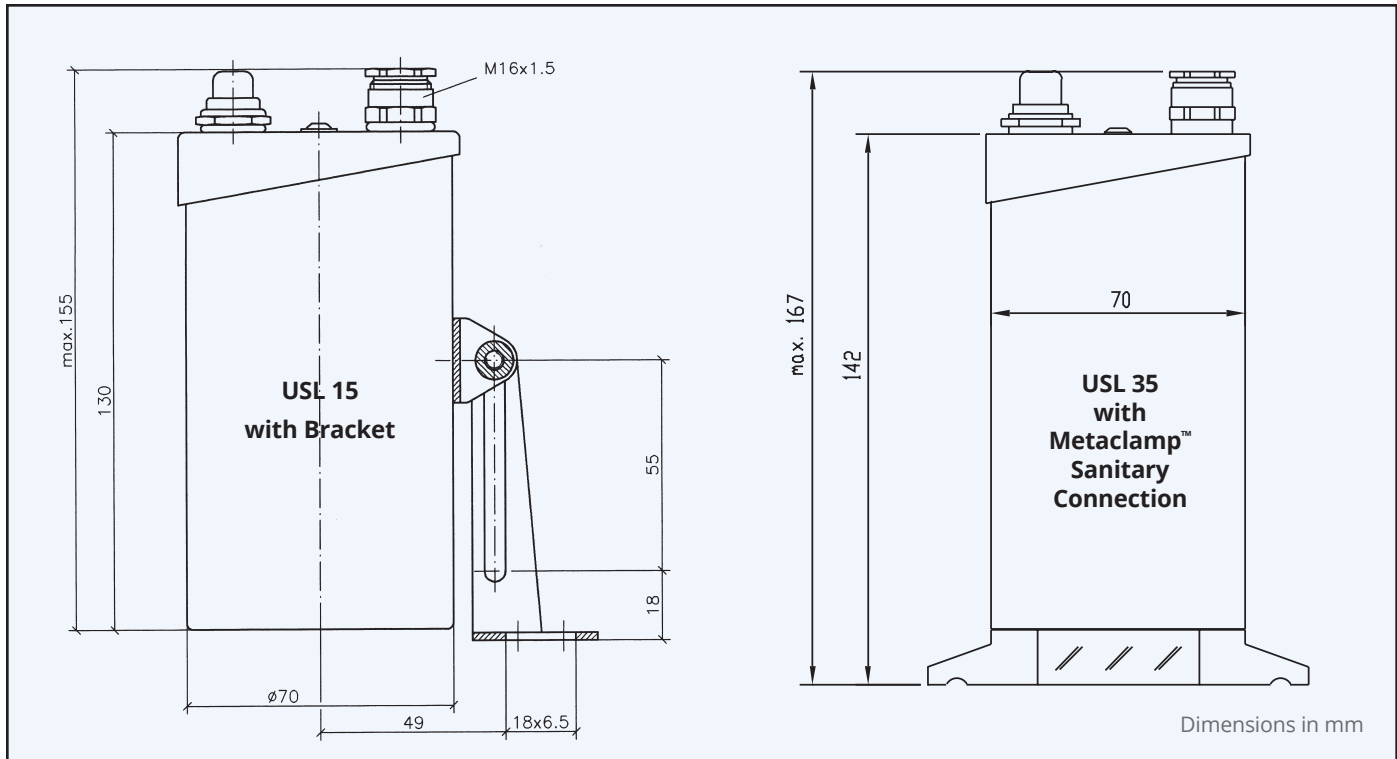

Components and Materials:

- Body and cap of luminaire: 316 Stainless Steel (1.4404)
- Fastener Components: 304 Stainless Steel (1.4301) (hinged bracket or flanged adapter collar for attachment to Weld-neck sight glass fitting MV sizes DN 50 & 65)
- Metaclamp sanitary clamp connection: Duplex Stainless Steel, Hastelloy or Monel with Borosilicate glass to DIN7080
- Optional polymer and metal sanitary clamp connection: 316 stainless steel with a transparent food grade polymer
- Connecting cable: 3 meter cable with cable gland or M12 Female Connector
- Weight: 2 lbs. (0.91 kg)

LumiStar2000 luminaires USL15/35 are suitable for mounting...

- With a fused Metaglas® sight glass for sanitary connections (MetaClamp®) for clamp fittings
- With a fused Metaglas® sight glass for aseptic weld-neck sight glass fittings, Series MV
- With a fused Metaglas® sight glass for TCI ClampConnect® and Bolt-Connect®
- With a fused Metaglas® sight glass for NA-Connect® fittings
- With a fused Metaglas® sight glass for VARIVENT® in-line housings

Ordering Information

Example: LumiStar2000 Luminaire Stainless Steel USL35, 24V/30W



LumiStar2000 USL 15/35 with programmable on/off switch.